

BENETECH MaxClean™

BXP1 Primary Belt Cleaner

The Benetech MaxClean product line is designed to maximize user benefits and extend the life of your belt conveyors.

Key Features & Benefits:

1. Stainless steel construction

Benefits:

- 304 stainless steel components for long service life
- Excellent for chemical, higher temperature and high performance applications
- Less maintenance

2. Tungsten carbide blades

Benefits:

- Designed exclusively for vulcanized conveyor belts to provide exceptional cleaning efficiency
- Ensures the longest wear life of any blade material in the market
- High performance tungsten carbide does not typically require blade retensioning during its service life

3. Segment blades and rubber cushions

Benefits:

- 8" blades and cushions can move easily to conform to the changes in the belt cover/surface
- Each blade is independently pressured by its own rubber cushion so it can maintain optimum blade tension as it wears
- High cycle fatigue resistance EPDM rubber cushions ensure optimum pressure during the life of the TC tips

4. Cleaner location

Benefits:

- Engineered to be specifically located on the discharge pulley below the centerline and out of the flow of materials
- Multiple suspension arm sizes allow the cleaner to be custom fit in the optimum location on the pulley and can fit in applications where space is limited
- Few parts and modular design make the cleaner easy to install

5. Adjustable screw tensioners

Benefits:

- Easy to install and setup
- Requires minimal maintenance
- Any work on the tensioners can be safely done from the sides of the conveyor

6. Works on reversing conveyors

Benefits:

- Install one on each pulley and the cleaners will work when the belt is running in either direction

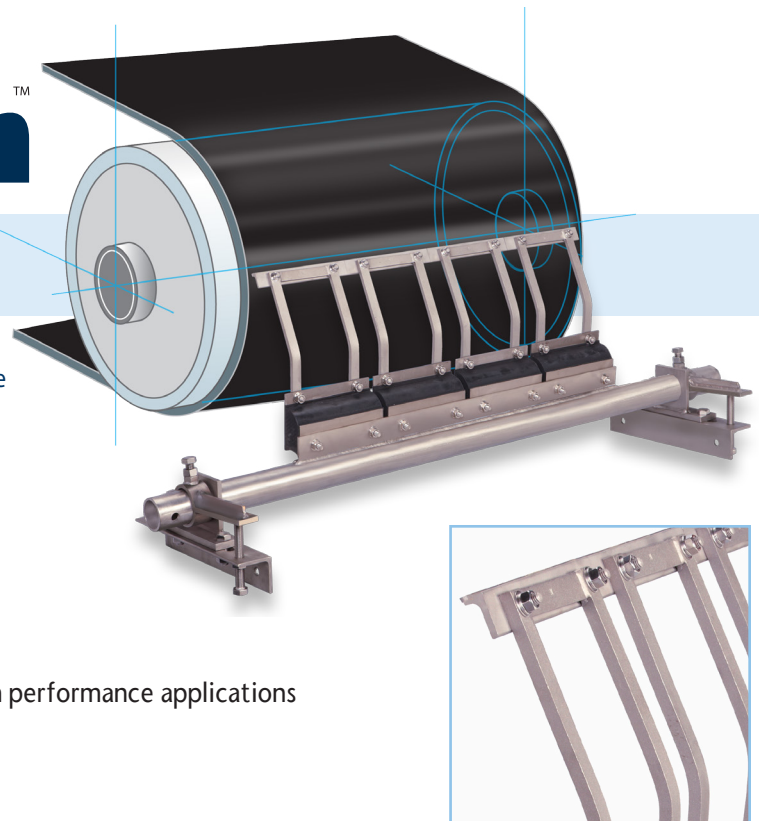

BXP1 Primary Belt Cleaner

Segmented Tungsten Carbide Blades and Rubber Cushions

- Segmented blades and cushions allow the cleaner to work the changing belt surface
- Tungsten carbide blades provide the longest service life on vulcanized belts
- Rubber cushions store tension and independently provide consistent pressure to each blade regardless of its wear rate
- These 8" wide, segmented components working together provide superior cleaning



BXP1 Pulley Diameter & Arm Size

Pulley Diameter in.	Belt Width mm.	Suspension Arm Size.	Arm Ordering Number
10 - 19	250-475	SS	BXP211
20 - 31	500-775	S	BXP212
32 - 39	800-975	M	BXP213
40 - 47	1000-1175	L	BXP214
48 - 67	1200-1675	LL	BXP215

BXP1 Ordering Information

Belt Width		Cleaner Ordering Number	Blades Req.	Arm Size	Tip Number
in.	mm.				
24	610	BXP1-024-1T1D2	3	SS	BXP11
24	610	BXP1-024-2T1D2	3	S	BXP12
24	610	BXP1-024-3T1D2	3	M	BXP13
30	762	BXP1-030-1T1D2	3	SS	BXP11
30	762	BXP1-030-2T1D2	3	S	BXP12
30	762	BXP1-030-3T1D2	3	M	BXP13
36	914	BXP1-036-1T1D2	4	SS	BXP11
36	914	BXP1-036-2T1D2	4	S	BXP12
36	914	BXP1-036-3T1D2	4	M	BXP13
36	914	BXP1-036-4T1D2	4	L	BXP14
42	1067	BXP1-042-1T1D2	5	SS	BXP11
42	1067	BXP1-042-2T1D2	5	S	BXP12
42	1067	BXP1-042-3T1D2	5	M	BXP13
42	1067	BXP1-042-4T1D2	5	L	BXP14
42	1067	BXP1-042-5T1D2	5	LL	BXP15

Belt Width		Cleaner Ordering Number	Blades Req.	Arm Size	Tip Number
in.	mm.				
48	1219	BXP1-048-1T1D2	6	SS	BXP11
48	1219	BXP1-048-2T1D2	6	S	BXP12
48	1219	BXP1-048-3T1D2	6	M	BXP13
48	1219	BXP1-048-4T1D2	6	L	BXP14
48	1219	BXP1-048-5T1D2	6	LL	BXP15
54	1372	BXP1-054-2T1D2	6	S	BXP11
54	1372	BXP1-054-3T1D2	6	M	BXP12
54	1372	BXP1-054-4T1D2	6	L	BXP13
54	1372	BXP1-054-5T1D2	6	LL	BXP14
60	1524	BXP1-060-2T1D2	7	S	BXP11
60	1524	BXP1-060-3T1D2	7	M	BXP12
60	1524	BXP1-060-4T1D2	7	L	BXP13
60	1524	BXP1-060-5T1D2	7	LL	BXP14
72	1829	BXP1-072-2T1D2	9	S	BXP11
72	1829	BXP1-072-3T1D2	9	M	BXP12
72	1829	BXP1-072-4T1D2	9	L	BXP13
72	1829	BXP1-072-5T1D2	9	LL	BXP14



Global Headquarters Benetech, Inc.
2245 Sequoia Drive, Suite 300,
Aurora, Illinois 60506

p: +1-630-844-1300
f: +1-630-844-8690
www.benetechglobal.com

USA